

LOC		DIST		P		F		ZONE		LTR		REVISIONS		DATE	APPD
CM	53												REV PER EC 0L30-0060-96	10-1-96	JH R5

1. BULK PACKAGED, UNASSEMBLED.
2. APPROVAL AGENCY LOGO LOCATED APPROXIMATELY AS SHOWN.
3. AMP LOGO LOCATED THIS SURFACE.
4. CIRCUIT NUMBER ONE IDENTIFICATION RIB AND CIRCUIT IDENTIFICATION NUMBERS ARE EACH LOCATED ADJACENT TO THE APPROPRIATE CIRCUIT CAVITIES.
5. NEW MOLD CONSTRUCTION PROVIDES MATERIAL REDUCTION CORING AT BASE OF SILOS WITH NO CORING AS OPTIONAL.
6. DIMENSION INDICATED IS AS MOLDED. ADDITIONAL GROWTH DUE TO SUBSEQUENT MOISTURE ABSORPTION MAY OCCUR.

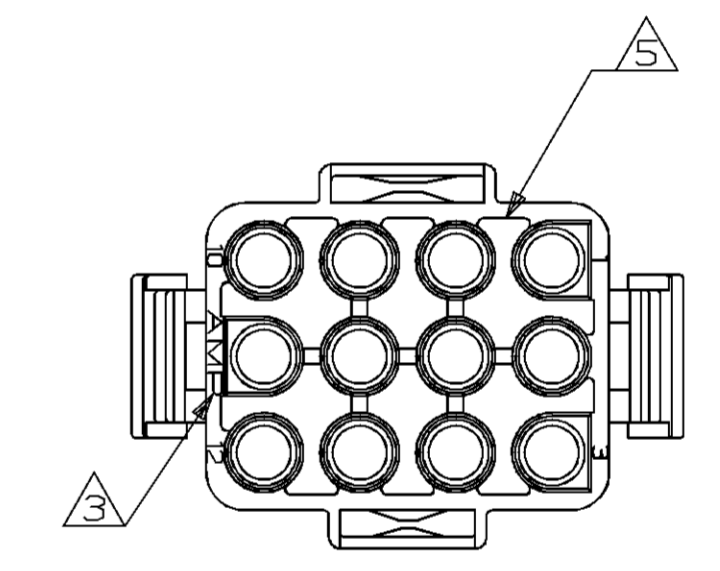
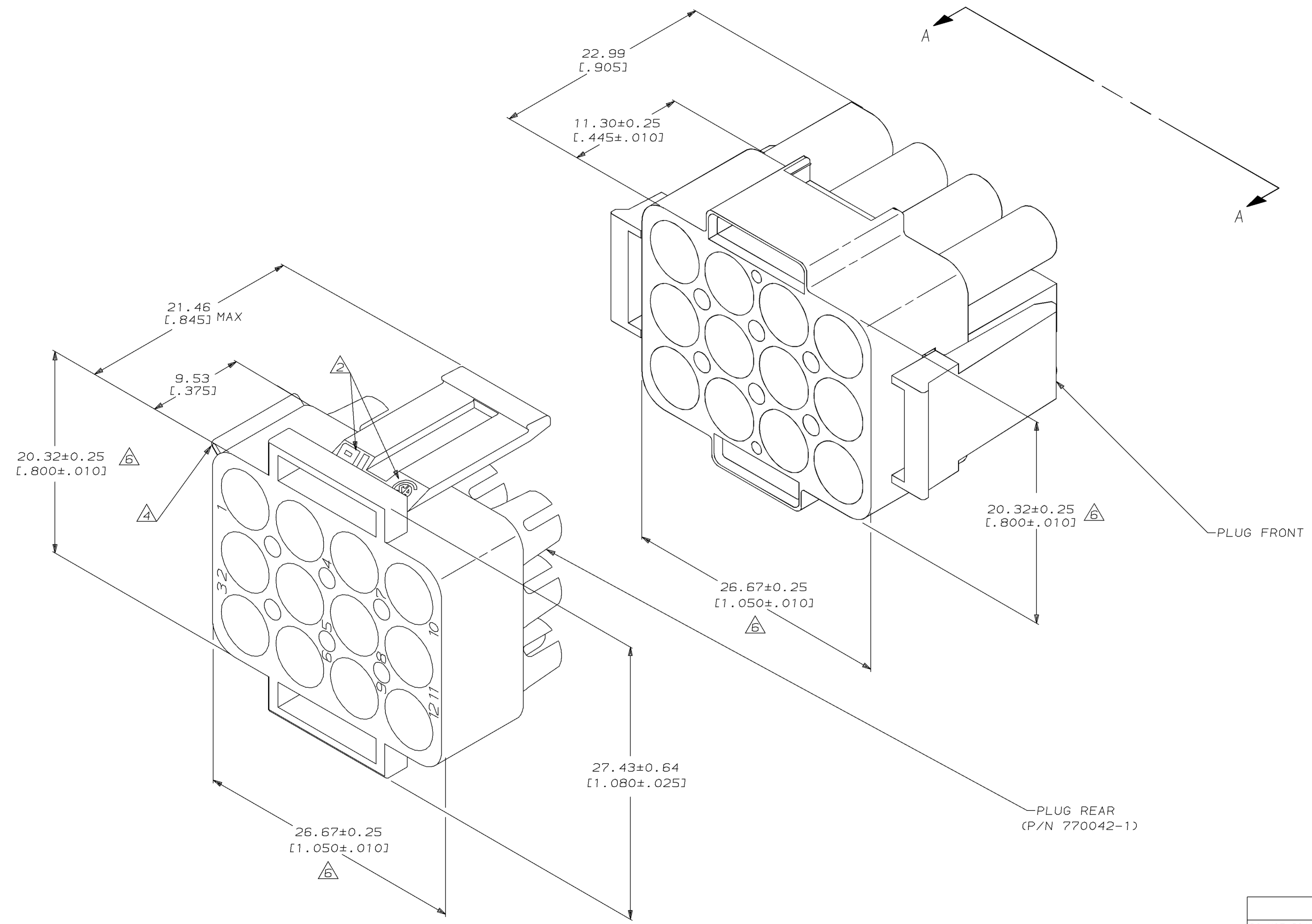

VIEW A-A  
SCALE 2:1

770022-1  
PART NUMBER

DO NOT SCALE PRINT. UNLESS SPECIFIED DIMENSIONS IN INCHES TOLERANCES ON:		DR 1-22-92 K. SALMON		PART NO	
1 ± 0.005		CHK 1-22-92 R. SWING		AMP INCORPORATED Harrisburg, Pa. 17105	
2 ± 0.005		APPD 1-22-92 M. TRULL		NAME	
3 ± 0.010		APPD 1-22-92 M. TRULL		PLUG HOUSING KIT, 12 CIRCUIT, UNIVERSAL MATE-N-LOK™ II	
ANGLES ± 0.13 [0.005]		PRODUCT SPEC		DRAWING NO	
MATERIAL		APPLICATION SPEC		770022	
NYLON, UL94V-0,		WEIGHT		SCALE 5:1	
FINISH		SCALE		SHEET 1 OF 1	

METRIC